



SMD Type Photo Diode with Daylight Filter

Features

- Small double-end package
- High reliability
- Spectral range of sensitivity: 760-1100nm
- Fast Response time
- RoHS compliance

Applications

- Infrared sensor

Description

The PDP91608BT11 is a silicon photo diode housed in a miniature SMD package. The device comes with a superior filtering for visible light by utilizing special black molding compound.

Package Outline

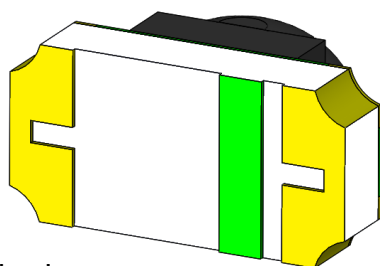
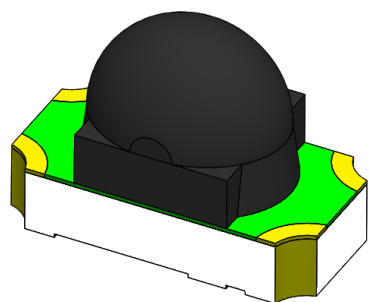

Cathode

Anode

Schematic





SMD Type Photo Diode with Daylight Filter

Absolute Maximum Rating at 25°C

Symbol	Parameters	Ratings	Units	Notes
V _R	Reverse Voltage	33	V	
T _{opr}	Operating Temperature	-40 ~ +85	°C	
T _{stg}	Storage Temperature	-40 ~ +100	°C	
T _{sol}	Soldering Temperature	260	°C	1
P _{to}	Total Power Dissipation	150	mW	

Electro-Optical Characteristics *TA = 25°C (unless otherwise specified)*

Optical Characteristics

Symbol	Parameters	Test Conditions	Min	Typ	Max	Units	Notes
λ	Spectral Bandwidth	-	760	-	1100	nm	
λ _P	Peak Sensitivity	-	-	900	-	nm	
θ _{1/2}	View Angle at X axis	V _R =5V	-	±52.5	-	deg	
	View Angle at Y axis		-	±47.5	-	deg	

Electrical Characteristics

Symbol	Parameters	Test Conditions	Min	Typ	Max	Units	Notes
I _D	Dark Current	Ee=0mW /cm ² V _R =10V	-	-	10	nA	
V _{BR}	Reverse Breakdown Voltage	Ee=0mW /cm ² I _R =100uA	33	-	-	V	
V _{OC}	Open-Circuit Voltage	Ee=1mW /cm ² λ _P =940nm	-	0.30	-	V	
I _{SC}	Short-Circuit Current		-	1.50	-	μA	
I _R	Reverse Light Current	Ee=1mW /cm ² λ _P =940nm, V _R =5V	1.0	1.83	-	μA	
C _T	Transition Capacitance	Ee=0mW /cm ² f=1MHz, V _R =5V	-	0.85	-	pF	



SMD Type Photo Diode with Daylight Filter

Switching Characteristics

Symbol	Parameters	Test Conditions	Min	Typ	Max	Units	Notes
t_r	Rise Time	$V_R = 10V, R_L = 10k\Omega$	-	400	-	ns	2
t_f	Fall Time		-	400	-		

Notes:

1 : Soldering time ≤ 5 seconds.

2 : Test circuit :

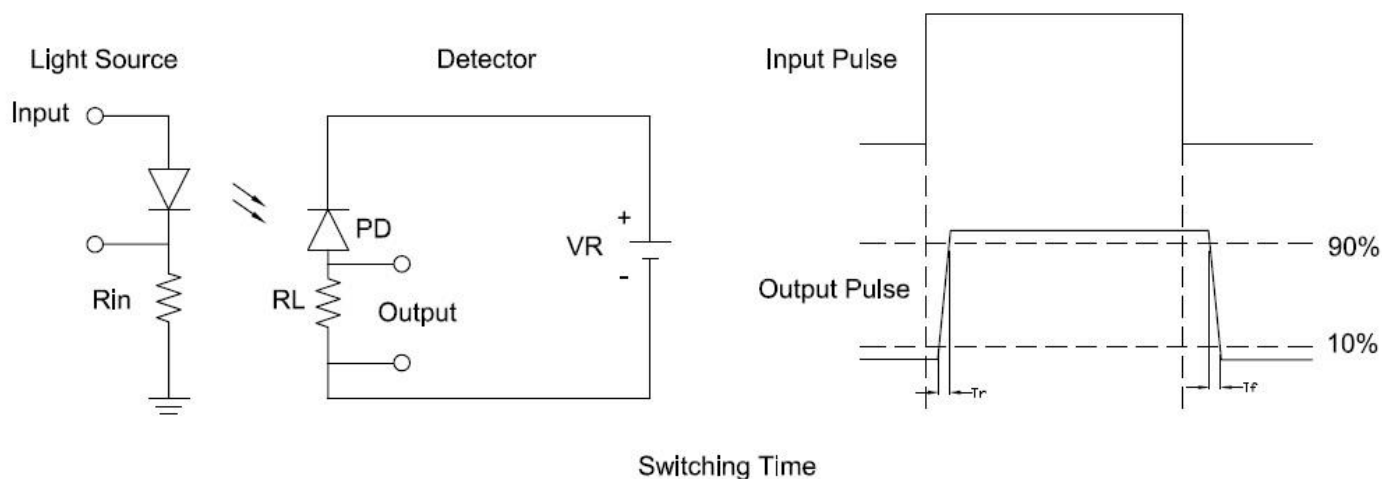



Typical Characteristic Curves

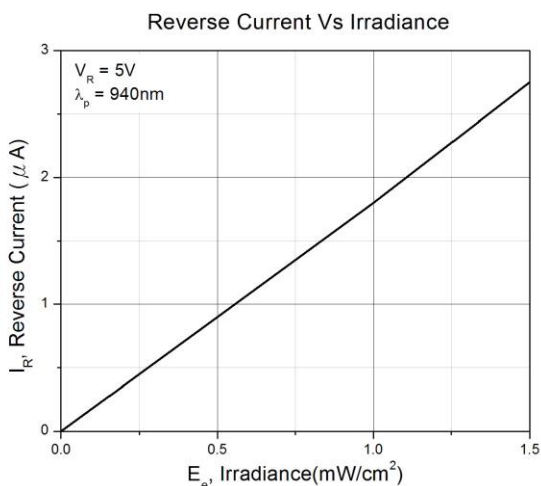

Figure 1

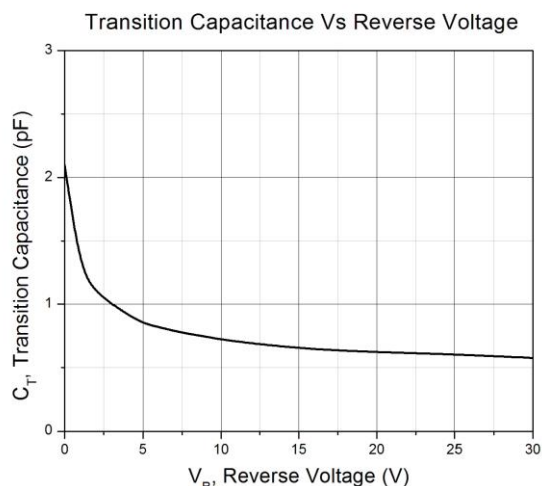

Figure 2

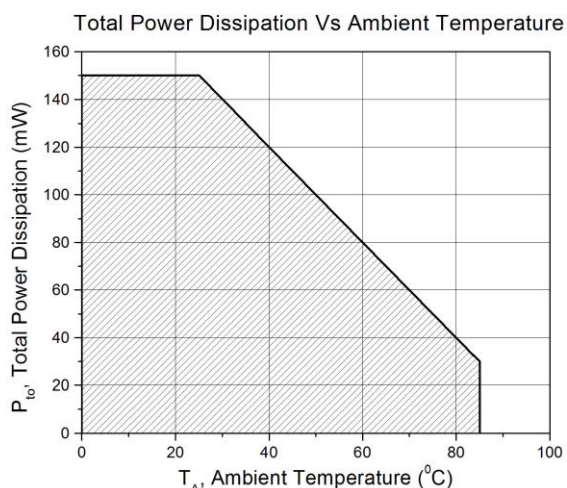

Figure 3

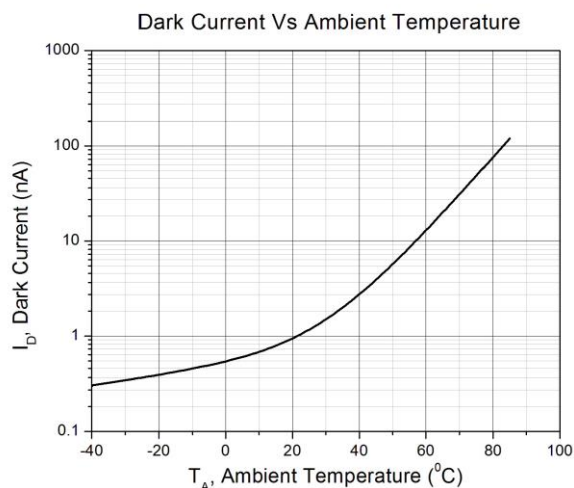

Figure 4

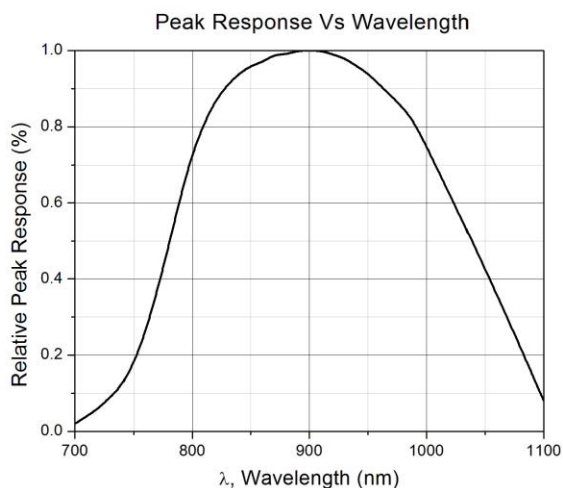

Figure 5

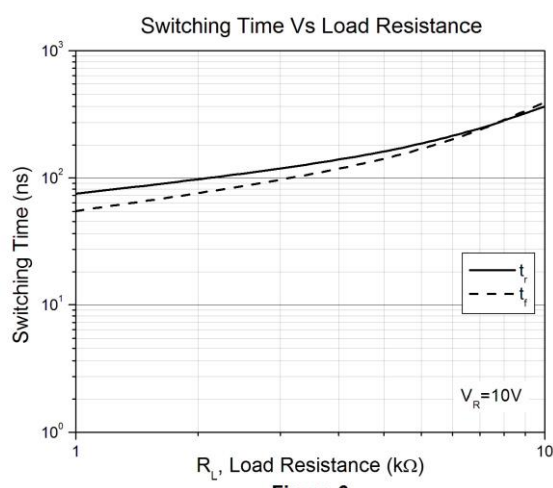

Figure 6



Typical Characteristic Curves

Angular Displacement at X axis

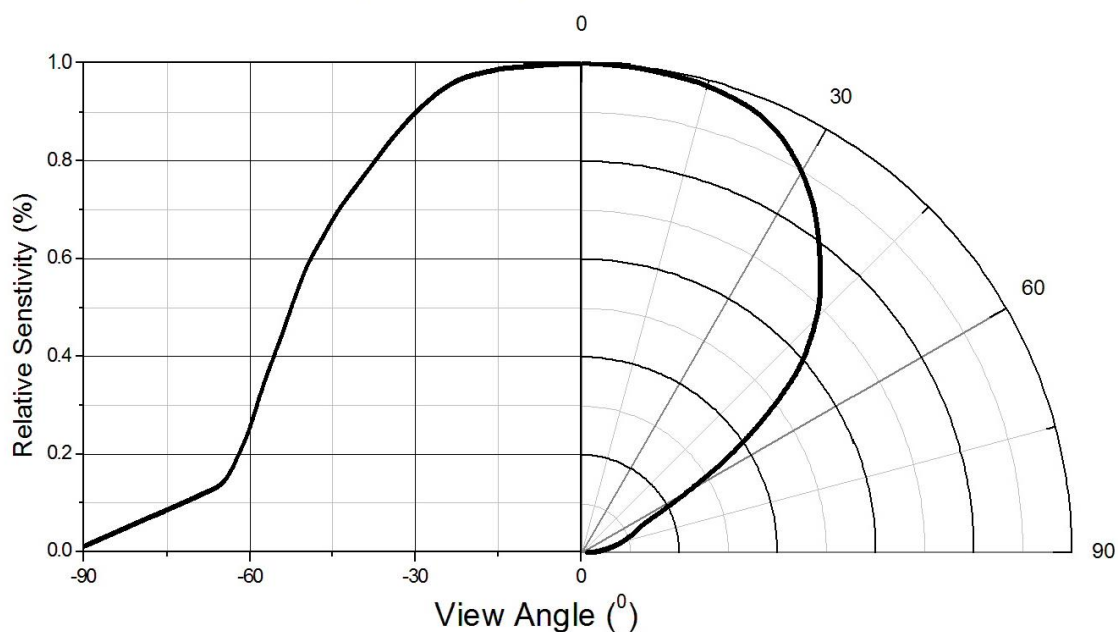

Figure 7

Angular Displacement at Y axis

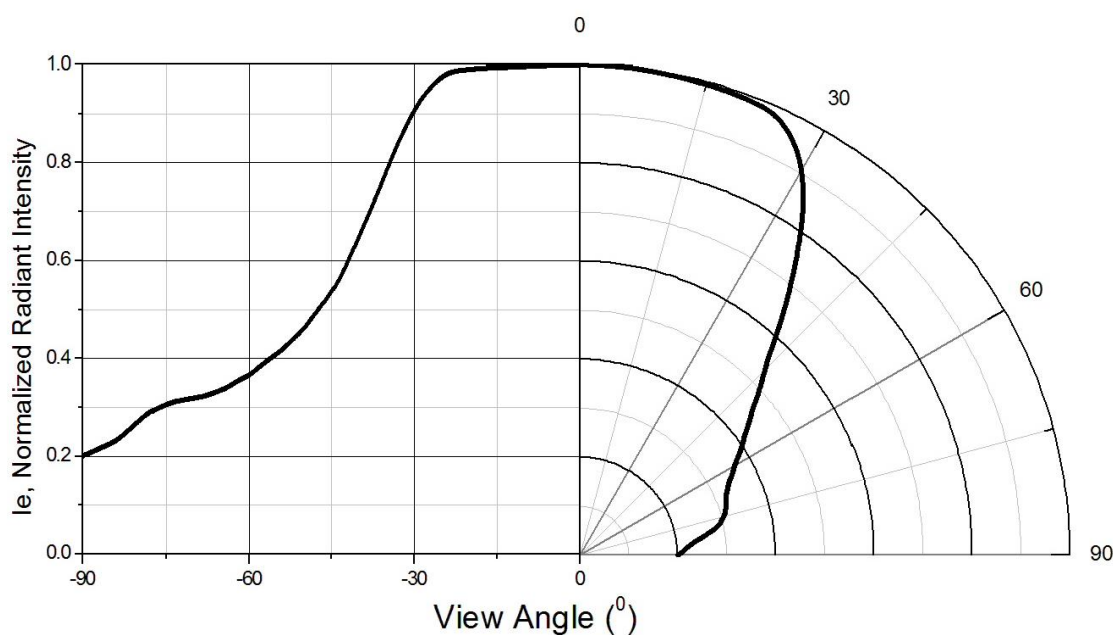
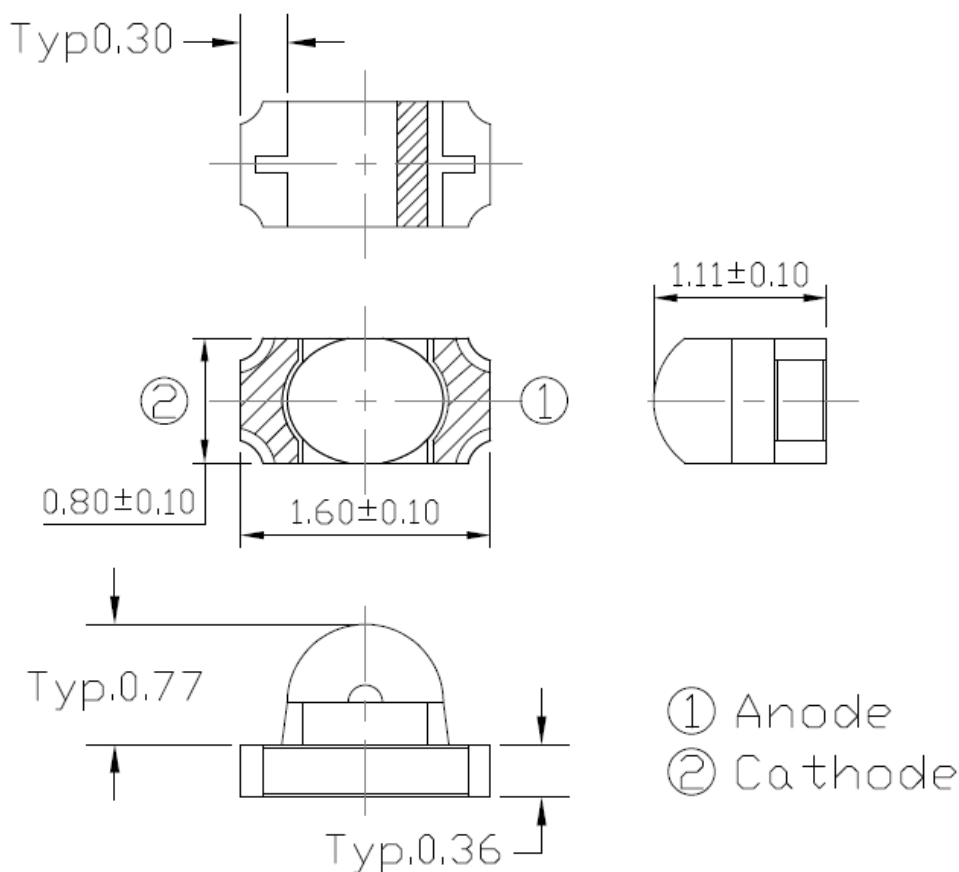

Figure 8



SMD Type Photo Diode with Daylight Filter

Package Dimension *All dimensions are in mm, unless otherwise stated*



Recommended Soldering Mask *All dimensions are in mm, unless otherwise stated*

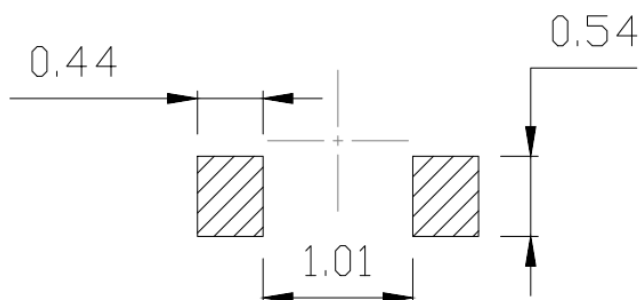

Ordering Information

Part Number	Description	Quantity
PDP91608BT11	Tape & Reel	3000 pcs



SMD Type Photo Diode with Daylight Filter

Reel Dimension *All dimensions are in mm, unless otherwise stated*

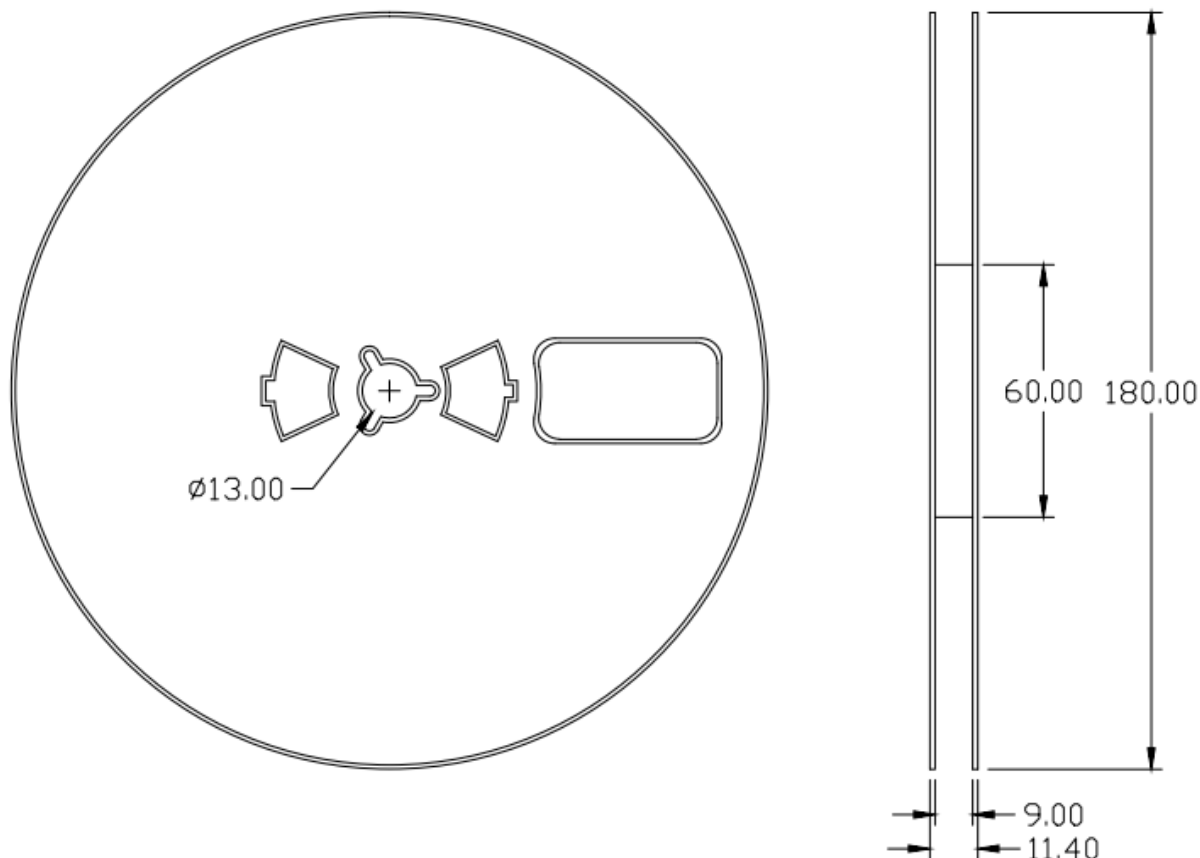

Tape Dimension *All dimensions are in mm, unless otherwise stated*

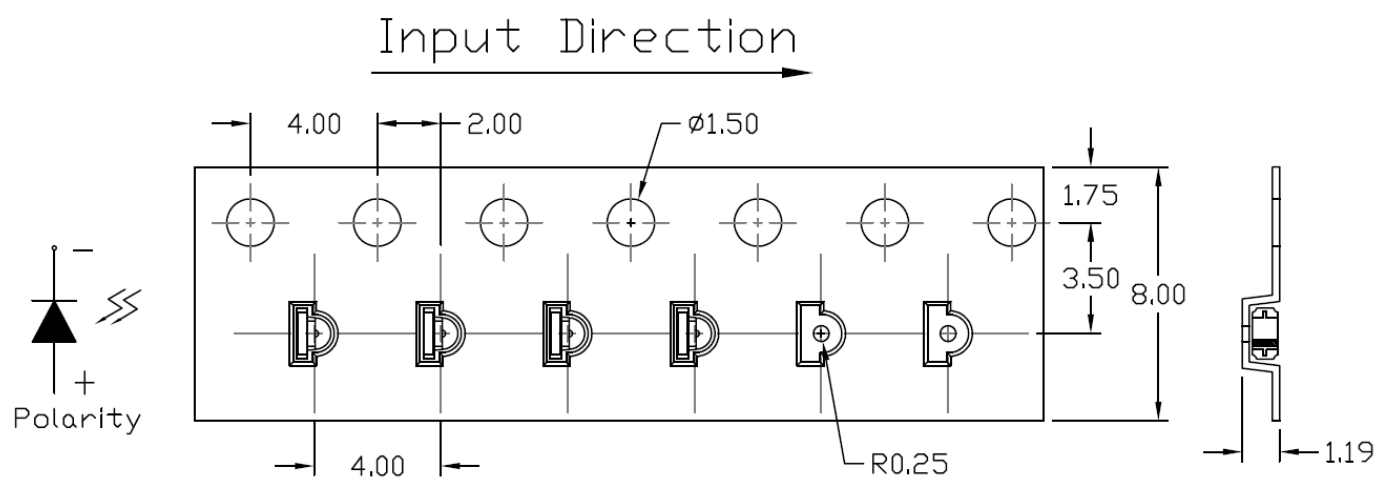



SMD Type Photo Diode with Daylight Filter

Reflow Profile

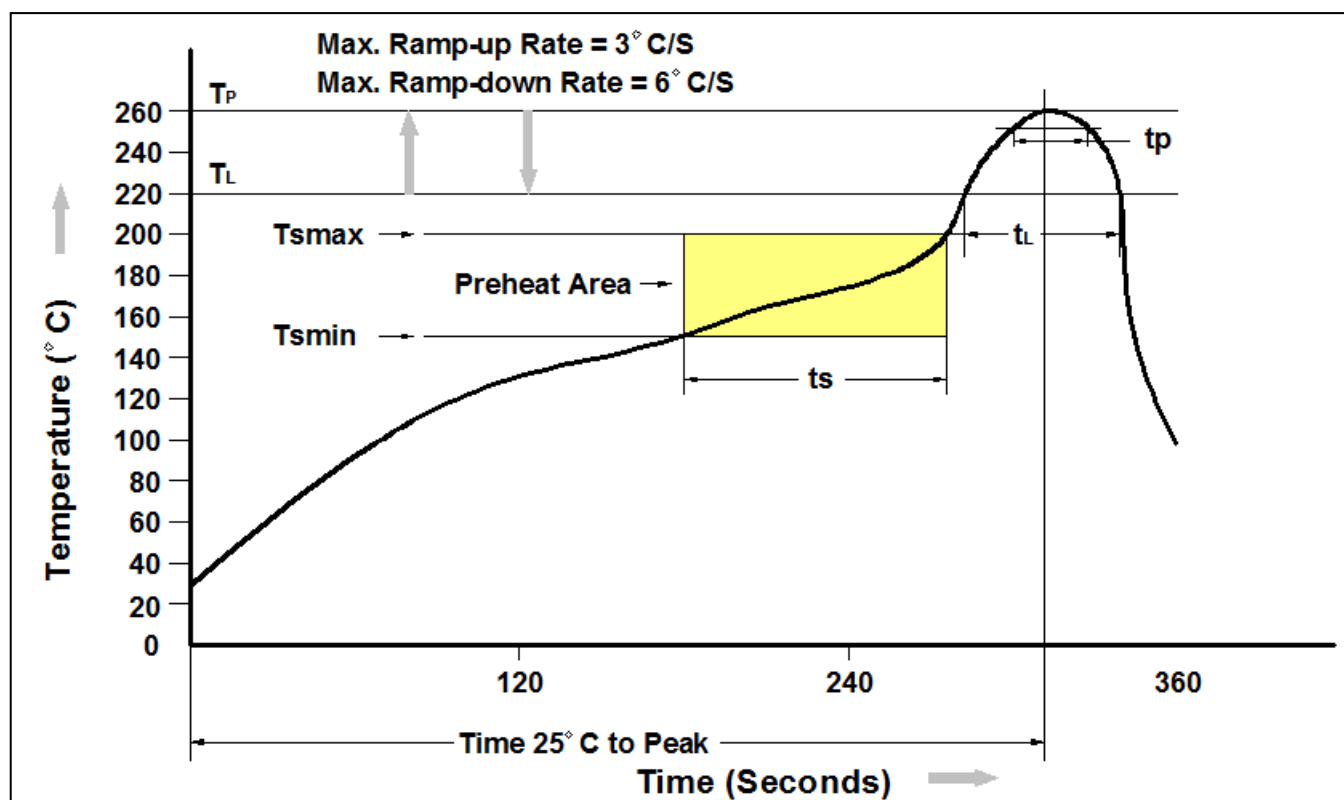

Profile Feature	Pb-Free Assembly Profile
Temperature Min. (T _{sm})	150°C
Temperature Max. (T _{sm})	200°C
Time (t _s) from (T _{sm} to T _{sm})	60-120 seconds
Ramp-up Rate (t _L to t _P)	3°C/second max.
Liquidous Temperature (T _L)	217°C
Time (t _L) Maintained Above (T _L)	60 – 150 seconds
Peak Body Package Temperature	260°C +0°C / -5°C
Time (t _P) within 5°C of 260°C	30 seconds
Ramp-down Rate (T _P to T _L)	6°C/second max
Time 25°C to Peak Temperature	8 minutes max.



SMD Type Photo Diode with Daylight Filter

DISCLAIMER

CT MICRO RESERVES THE RIGHT TO MAKE CHANGES WITHOUT FURTHER NOTICE TO ANY PRODUCTS HEREIN TO IMPROVE RELIABILITY, FUNCTION OR DESIGN. CT MICRO DOES NOT ASSUME ANY LIABILITY ARISING OUT OF THE APPLICATION OR USE OF ANY PRODUCT OR CIRCUIT DESCRIBED HEREIN; NEITHER DOES IT CONVEY ANY LICENSE UNDER ITS PATENT RIGHTS, NOR THE RIGHTS OF OTHERS.

CT MICRO ARE NOT AUTHORIZED FOR USE AS CRITICAL COMPONENTS IN LIFE SUPPORT DEVICES OR SYSTEMS WITHOUT EXPRESS WRITTEN APPROVAL OF CT MICRO INTERNATIONAL CORPORATION.

- 1. Life support devices or systems are devices or systems which, (a) are intended for surgical implant into the body, or (b) support or sustain life, or (c) whose failure to perform when properly used in accordance with instruction for use provided in the labelling, can be reasonably expected to result in significant injury to the user.*
- 2. A critical component is any component of a life support device or system whose failure to perform can be reasonably expected to cause the failure of the life support device or system, or to affect its safety or effectiveness.*