



# GC283507-ETC4

## SMD Type Green Emitter

### Features

- Top view 2835 package
- Viewing Angle =  $\pm 60^\circ$
- Compatible with infrared and vapor phase reflow solder process
- High reliability
- Ultra bright Green
- RoHS compliance

### Applications

- Optical indicator.
- Switch and Symbol Display.

### Description

The GC283507-ETC4 is an AlGaInP Green LED housed in a miniature SMD package. The device has a dominant wavelength of 522nm LED.

### Package Outline

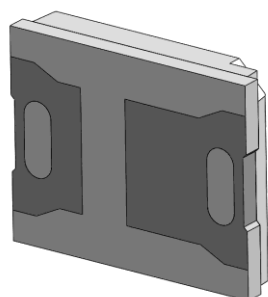
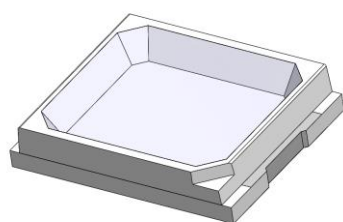

Anode

Cathode

### Schematic

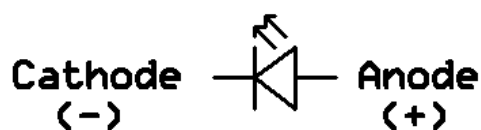



# GC283507-ETC4

## SMD Type Green Emitter

### Absolute Maximum Rating at 25°C

Symbol	Parameters	Ratings	Units	Notes
I <sub>F</sub>	Continuous Forward Current	30	mA	
I <sub>FP</sub>	Peak Forward Current	90	mA	1
V <sub>R</sub>	Reverse Voltage	5	V	
T <sub>opr</sub>	Operating Temperature	-40 ~ +85	°C	
T <sub>stg</sub>	Storage Temperature	-40 ~ +100	°C	
T <sub>sol</sub>	Soldering Temperature	260	°C	2
P <sub>D</sub>	Power Dissipation at(or below) 25°C Free Air Temperature	100	mW	

### Electro-Optical Characteristics *TA = 25°C (unless otherwise specified)*

#### Optical Characteristics

Symbol	Parameters	Test Conditions	Min	Typ	Max	Units	Notes
I <sub>v</sub>	Luminous Intensity	I <sub>F</sub> =30mA	1800	-	4500	mcd	3
λ <sub>d</sub>	Dominant Wavelength	I <sub>F</sub> =30mA	515	-	530	nm	4
θ <sub>1/2</sub>	Angle of Half Intensity	I <sub>F</sub> =30mA	-	±60	-	deg	

#### Electrical Characteristics

Symbol	Parameters	Test Conditions	Min	Typ	Max	Units	Notes
V <sub>F</sub>	Forward Voltage	I <sub>F</sub> =30mA	3.05	-	3.95	V	5
I <sub>R</sub>	Reverse Current	V <sub>R</sub> =5V	-	-	1	μA	

#### Notes:

1. I<sub>FP</sub> Conditions--Pulse Width ≤ 100μs and Duty ≤ 10%.
2. Soldering time ≤ 10 seconds.
3. Bin Range of Luminous Intensity

Bin Code	Min	Max	Unit	Condition
X1	1800	2250	mcd	I <sub>F</sub> =30mA
X2	2250	2850		
Y1	2850	3600		
Y2	3600	4500		

Tolerance of: Luminous Intensity ±10%



# GC283507-ETC4

## SMD Type Green Emitter

### 4. Bin Range of Dominant Wavelength

Bin Code	Min	Max	Unit	Condition
A4	515	520	nm	I <sub>F</sub> =30mA
A5	520	525		
A6	525	530		

Tolerance of Dominant Wavelength: ±1nm.

### 5. Bin Range of Forward Voltage

Bin Code	Min	Max	Unit	Condition
6	3.05	3.35	V	I <sub>F</sub> =30mA
7	3.35	3.65		
8	3.65	3.95		

Tolerance of Forward Voltage ±0.1V.



# GC283507-ETC4

## SMD Type Green Emitter

### Typical Characteristic Curves

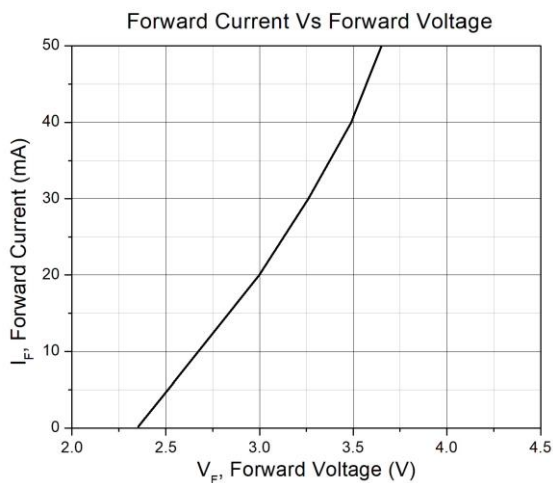

Figure 1

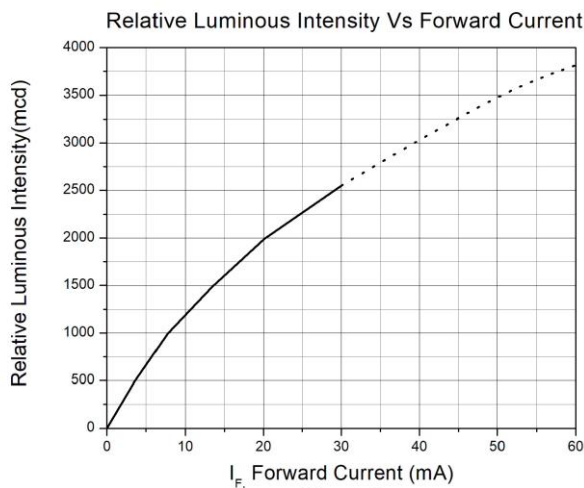

Figure 2

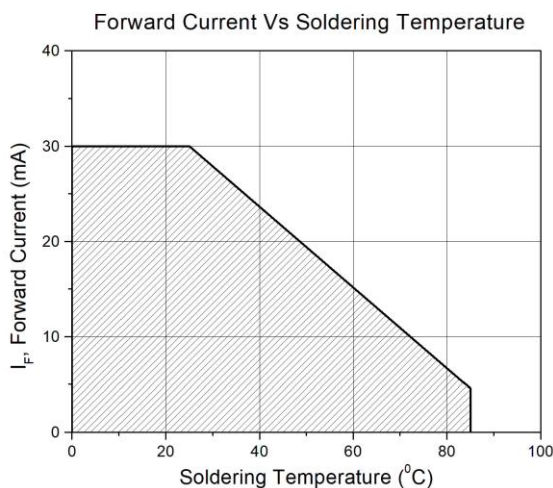

Figure 3

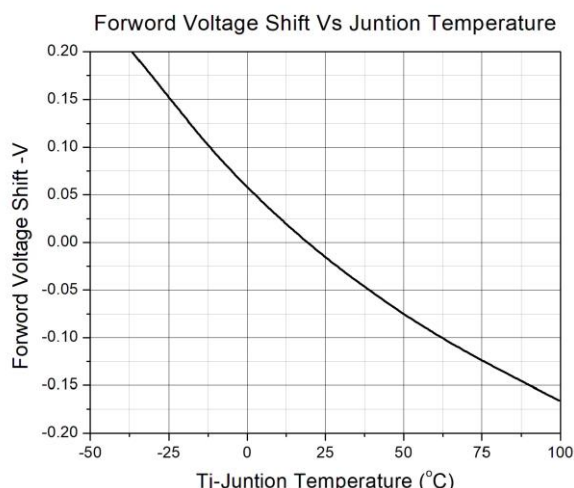

Figure 4

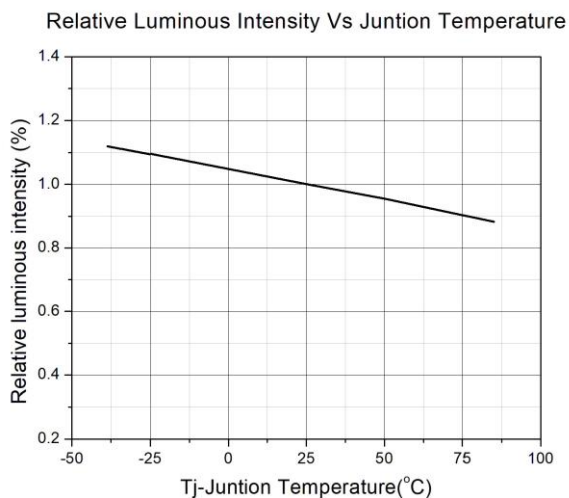

Figure 5

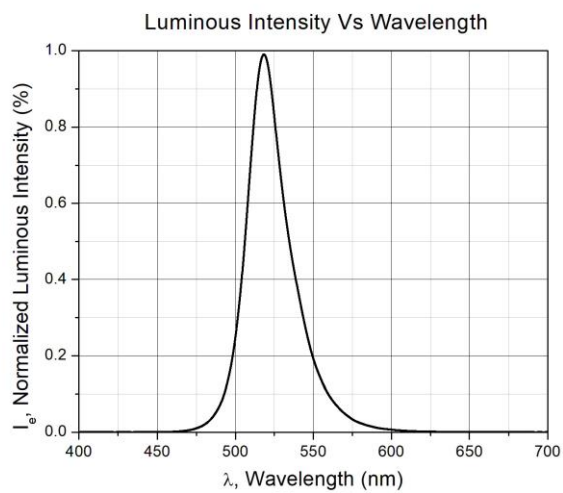

Figure 6



## Typical Characteristic Curves

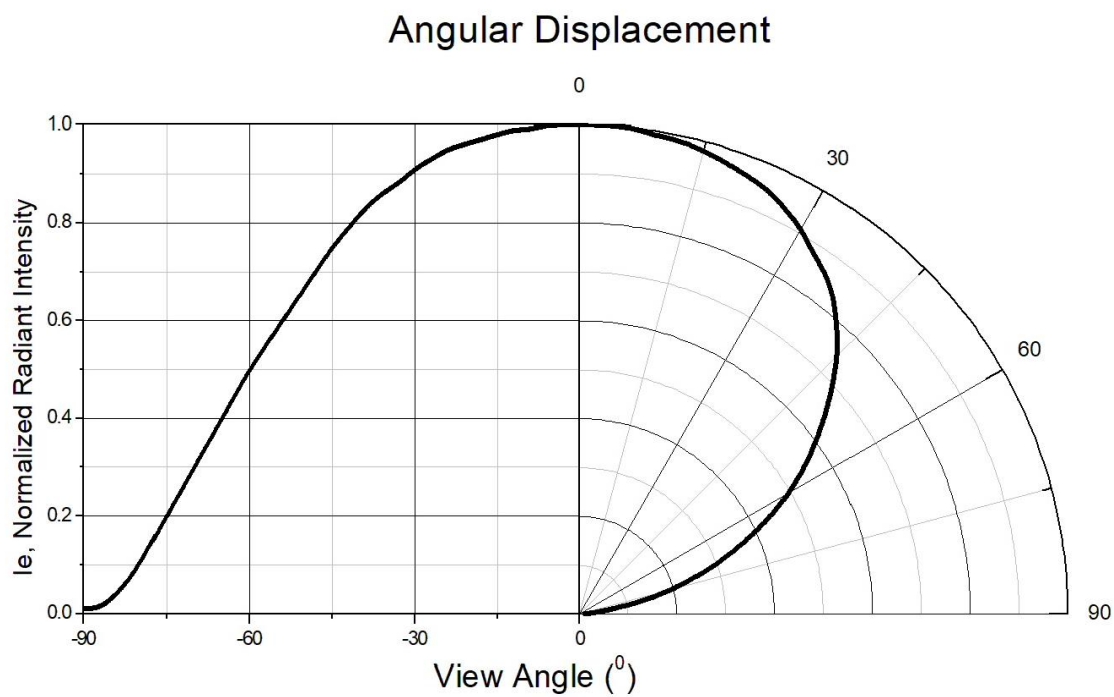

Figure 7



# GC283507-ETC4

## SMD Type Green Emitter

### Package Dimension *All dimensions are in mm, unless otherwise stated*

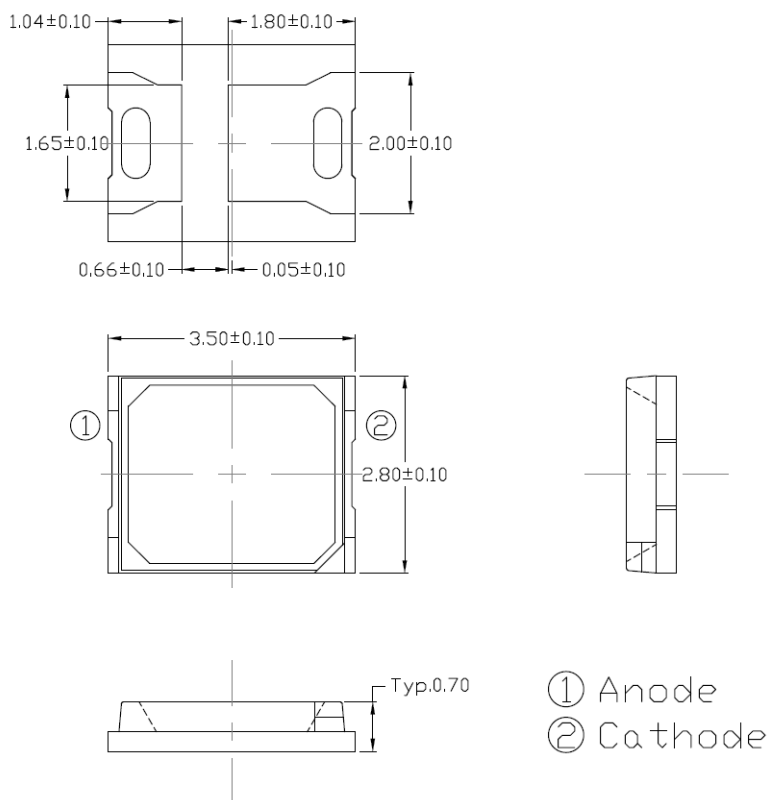

Note: Tolerance unless mentioned is ±0.1mm.

### Recommended Soldering Mask *All dimensions are in mm, unless otherwise stated*

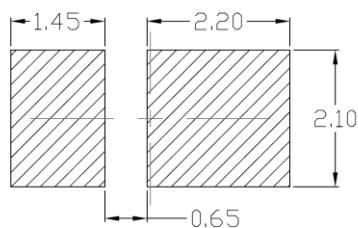

Note: Tolerance unless mentioned is ±0.1mm.

### Ordering Information

<b>Part Number</b>	<b>Description</b>	<b>Quantity</b>
GC283507-ETC4	Tape & Reel	4000 pcs



# GC283507-ETC4

## SMD Type Green Emitter

### Reel Dimension

All dimensions are in mm, unless otherwise stated

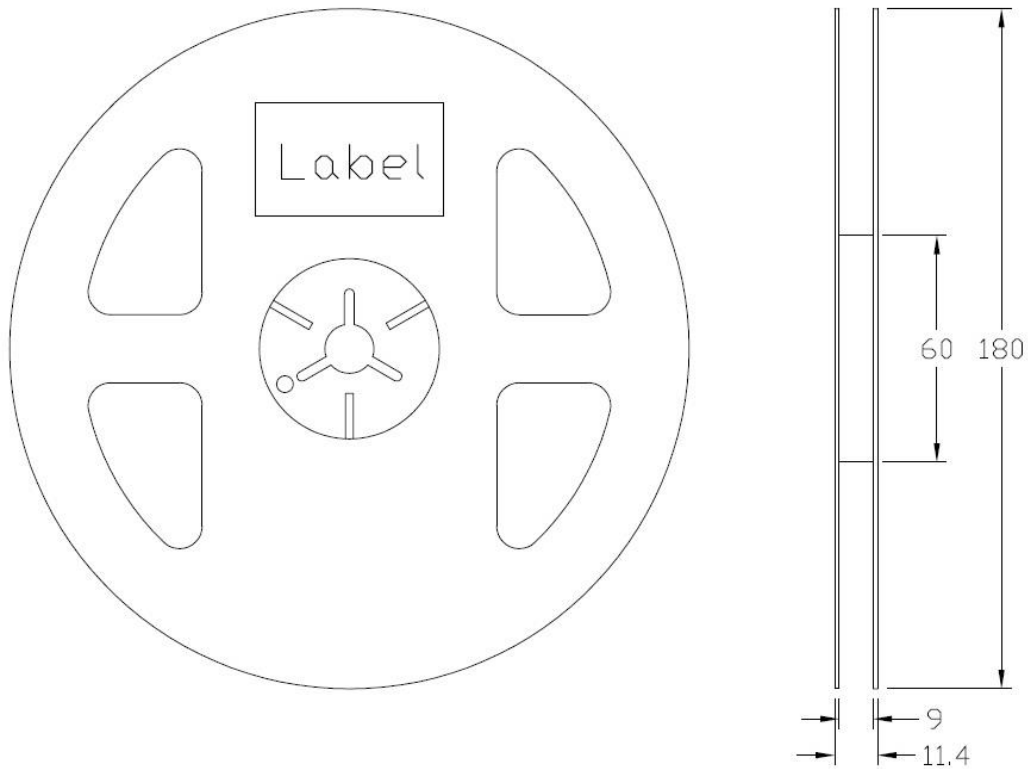

### Tape Dimension

All dimensions are in mm, unless otherwise stated

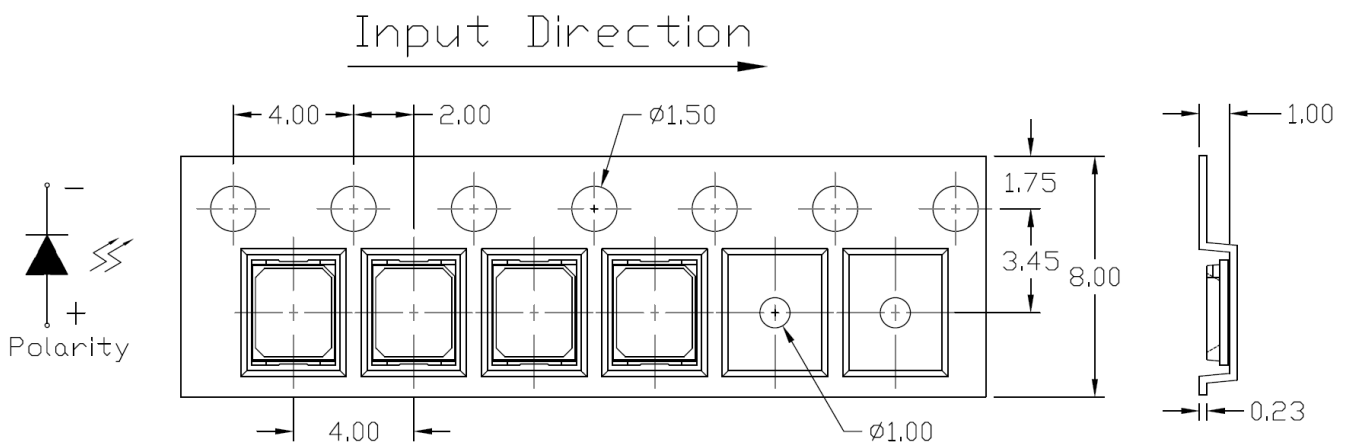

Note: Tolerance unless mentioned is  $\pm 0.1$ mm.



### Label Form Specification

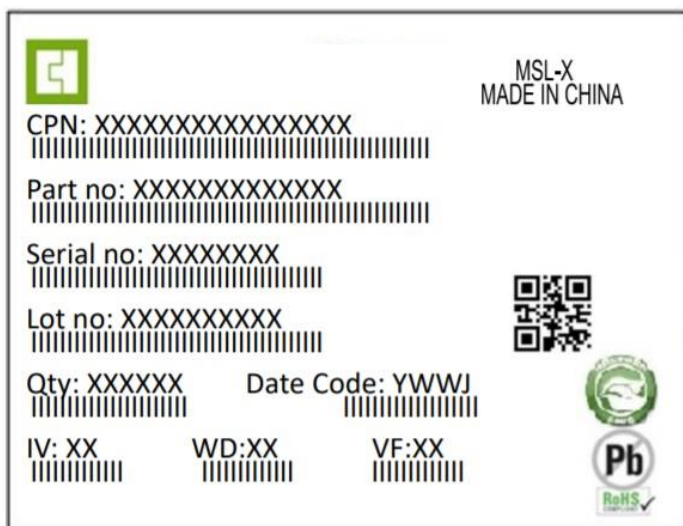

CPN : Customer Part Number  
 Part no: CTM Production Number  
 Serial no: Production Number  
 Lot no: Lot number  
 Q'ty: Packing Quantity  
 Date Code: Manufacture Date  
 IV : Bin Code of Luminous Intensity  
 WD : Bin Code of Dominant Wavelength  
 VF : Bin Code of Forward Voltage  
 MADE IN CHINA: Production Place

### Storage Condition

1. Do not open moisture proof bag before the products are ready to use.
2. The moisture barrier bag should be stored at 30°C and 90%R.H. max. before opening.  
Shelf life of non-opened bag is 12 months after the bag sealing date.
3. After opening the moisture barrier bag floor life is 168h at 30°C/60%RH. max. Unused LEDs should be resealed into moisture barrier bag. (Refer to J-STD-020 Standard)
4. If the moisture absorbent material has faded away or the LEDs have exceeded the storage time, baking treatment should be performed using the J-STD-033 Standard conditions.





Reflow Profile

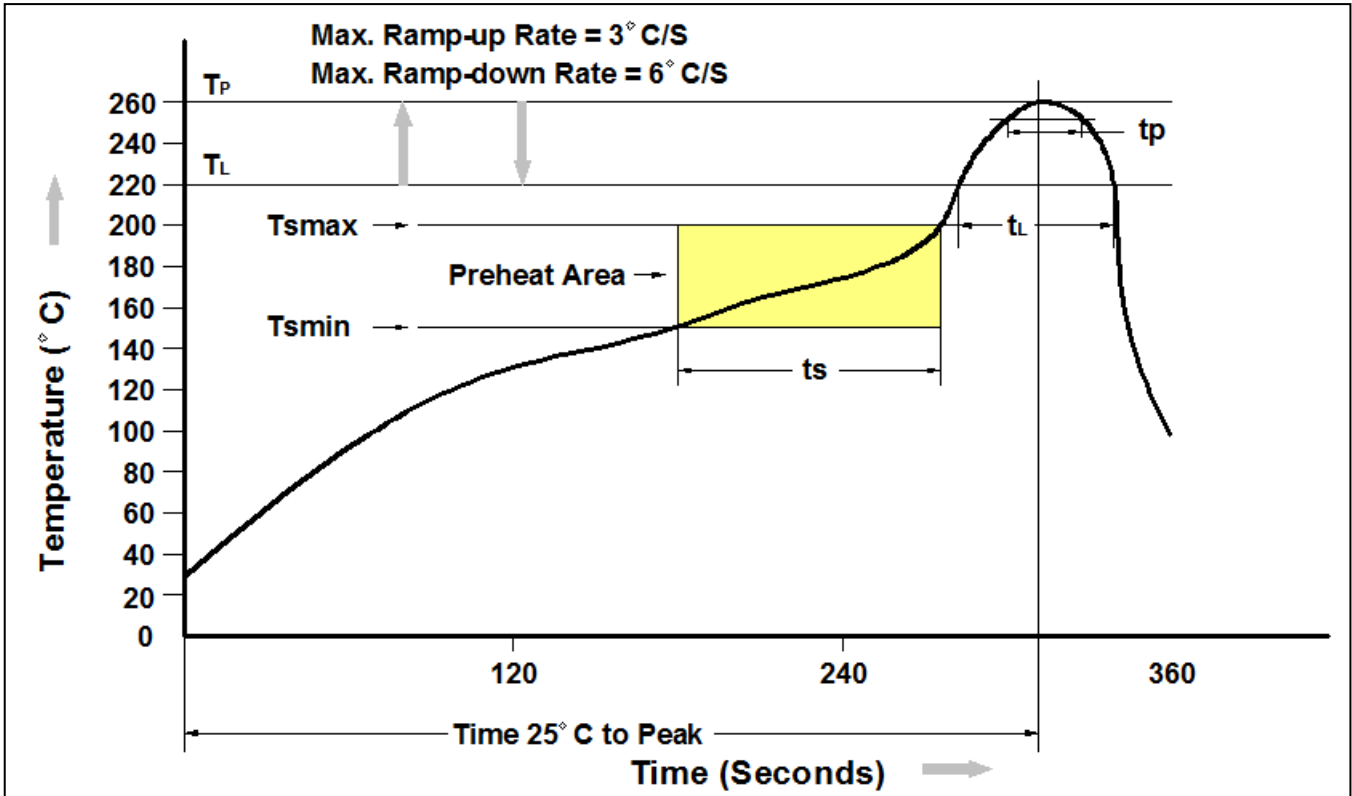

Profile Feature	Pb-Free Assembly Profile
Temperature Min. (T <sub>smin</sub> )	150°C
Temperature Max. (T <sub>smax</sub> )	200°C
Time (t <sub>s</sub> ) from (T <sub>smin</sub> to T <sub>smax</sub> )	60-120 seconds
Ramp-up Rate (t <sub>L</sub> to t <sub>P</sub> )	3°C/second max.
Liquidous Temperature (T <sub>L</sub> )	217°C
Time (t <sub>L</sub> ) Maintained Above (T <sub>L</sub> )	60 – 150 seconds
Peak Body Package Temperature	260°C +0°C / -5°C
Time (t <sub>P</sub> ) within 5°C of 260°C	30 seconds
Ramp-down Rate (T <sub>P</sub> to T <sub>L</sub> )	6°C/second max
Time 25°C to Peak Temperature	8 minutes max.



## DISCLAIMER

CT MICRO RESERVES THE RIGHT TO MAKE CHANGES WITHOUT FURTHER NOTICE TO ANY PRODUCTS HEREIN TO IMPROVE RELIABILITY, FUNCTION OR DESIGN. CT MICRO DOES NOT ASSUME ANY LIABILITY ARISING OUT OF THE APPLICATION OR USE OF ANY PRODUCT OR CIRCUIT DESCRIBED HEREIN; NEITHER DOES IT CONVEY ANY LICENSE UNDER ITS PATENT RIGHTS, NOR THE RIGHTS OF OTHERS.

---

CT MICRO ARE NOT AUTHORIZED FOR USE AS CRITICAL COMPONENTS IN LIFE SUPPORT DEVICES OR SYSTEMS WITHOUT EXPRESS WRITTEN APPROVAL OF CT MICRO INTERNATIONAL CORPORATION.

- 1. Life support devices or systems are devices or systems which, (a) are intended for surgical implant into the body, or (b) support or sustain life, or (c) whose failure to perform when properly used in accordance with instruction for use provided in the labelling, can be reasonably expected to result in significant injury to the user.*
- 2. A critical component is any component of a life support device or system whose failure to perform can be reasonably expected to cause the failure of the life support device or system, or to affect its safety or effectiveness.*