



Low Input Current Photodarlington Coupler

Absolute Maximum Rating at 25°C

| Symbol | Parameters | Ratings | Units | Notes |
|-----------------------|---|------------|-------------------|-------|
| V _{ISO} | Isolation voltage | 5000 | V _{RMS} | |
| V _{IORM} | Maximum repetitive peak isolation voltage | 850 | V _{peak} | |
| V _{PR} | Input-to-Output Test Voltage, Method b, V _{IORM} × 1.875 = V _{PR} , 100% Production Test with t _m = 1 sec, Partial Discharge < 5 pC | 1594 | V _{peak} | 1 |
| V _{PR} | Input-to-Output Test Voltage, Method a, V _{IORM} × 1.6 = V _{PR} , Type and Sample Test, t _m = 10sec, Partial Discharge < 5 pC | 1360 | V _{peak} | 1 |
| V _{IOTM} | Maximum transient isolation voltage | 6000 | V _{peak} | |
| T _{OPR} | Operating temperature | -55 ~ +100 | °C | |
| T _{STG} | Storage temperature | -55 ~ +125 | °C | |
| T _{SOL} | Soldering temperature | 260 | °C | |
| Emitter | | | | |
| I _F | Forward current | 25 | mA | |
| I _{FP} | Peak forward current (50% duty, 1ms P.W) | 50 | mA | |
| I _{F(TRANS)} | Peak transient current (≤1μs P.W,300pps) | 1 | A | |
| V _R | Reverse voltage | 5 | V | |
| P _D | Power dissipation | 40 | mW | |
| Detector | | | | |
| P _D | Power dissipation | 100 | mW | |
| V _{EBR} | Emitter-Base reverse voltage | 0.5 | V | |
| I _O | Output Current | 60 | mA | |
| V _O | Output voltage | 6N138 | -0.5 to 7 | V |
| | | 6N139 | -0.5 to 18 | V |
| V _{CC} | Supply voltage | 6N138 | -0.5 to 7 | V |
| | | 6N139 | -0.5 to 18 | V |



Low Input Current Photodarlington Coupler

Electrical Characteristics $T_A = 0 - 70^\circ\text{C}$, $V_{CC}=4.5\text{V}$ (unless otherwise specified).

Emitter Characteristics

| Symbol | Parameters | Test Conditions | Min | Typ | Max | Units | Notes |
|-------------------------|--|---------------------|-----|------|-----|----------------------------|-------|
| V_F | Forward voltage | $I_F = 16\text{mA}$ | - | 1.45 | 1.6 | V | |
| I_R | Reverse Current | $V_R = 5\text{V}$ | - | - | 5 | μA | |
| $\Delta V_F/\Delta T_A$ | Temperature coefficient of forward voltage | $I_F = 16\text{mA}$ | - | -1.8 | - | $\text{mV}/^\circ\text{C}$ | |

Detector Characteristics

| Symbol | Parameters | Test Conditions | Min | Typ | Max | Units | Notes |
|-----------|---------------------------|---|-------|-------|-----|---------------|-------|
| I_{OH} | Logic High Output Current | $I_F=0\text{mA}$, $V_O=V_{CC}=18\text{V}$, | - | 0.008 | 80 | μA | |
| | | | 6N139 | - | - | | |
| I_{CCL} | Logic Low Supply Current | $I_F=1.6\text{mA}$, $V_O=\text{Open}$, $V_{CC}=18\text{V}$ | - | 0.5 | 1.4 | mA | |
| I_{CCH} | Logic High Supply Current | $I_F=0\text{mA}$, $V_O=\text{Open}$, $V_{CC}=18\text{V}$ | - | 0.04 | 8 | μA | |

Transfer Characteristics

| Symbol | Parameters | Test Conditions | Min | Typ | Max | Units | Notes |
|----------|--------------------------|-----------------|---|-----|------|-------|-------|
| CTR | Current Transfer Ratio | 6N139 | $I_F=0.5\text{mA}$, $V_O=0.4\text{V}$, | 400 | 2500 | - | % |
| | | 6N138 | $I_F=1.6\text{mA}$, $V_O=0.5\text{V}$, | 300 | 2000 | - | |
| | | 6N139 | | 500 | 2000 | - | |
| V_{OL} | Logic Low Output Voltage | 6N139 | $I_F= 0.5\text{mA}$, $I_O= 2\text{mA}$ | - | 0.04 | 0.4 | V |
| | | | $I_F= 1.6\text{mA}$, $I_O= 8\text{mA}$ | - | 0.08 | 0.4 | |
| | | | $I_F= 5\text{mA}$, $I_O= 15\text{mA}$ | - | 0.11 | 0.4 | |
| | | | $I_F= 12\text{mA}$, $I_O= 24\text{mA}$ | - | 0.16 | 0.4 | |
| | | 6N138 | $I_F= 1.6\text{mA}$, $I_O= 4.8\text{mA}$ | - | 0.05 | 0.4 | |



Low Input Current Photodarlington Coupler

Electrical Characteristics $T_A = 0 - 70^\circ\text{C}$, $V_{CC} = 5\text{V}$ (unless otherwise specified).

Switching Characteristics

| Symbol | Parameters | Test Conditions | Min | Typ | Max | Units | Notes |
|-----------|--|---|---|-----|------|-----------------|---------------|
| T_{PHL} | High to Low Propagation Delay | 6N139 | $I_F = 0.5\text{mA}$, $R_L = 4.7\text{k}\Omega$ | - | - | 30 | μs |
| | | | $T_A = 25^\circ\text{C}$ | - | 4.8 | 25 | |
| | | 6N138 | $I_F = 12\text{mA}$, $R_L = 250\Omega$ | - | - | 2 | |
| | | | $T_A = 25^\circ\text{C}$ | - | 0.2 | 1 | |
| | | 6N138 | $I_F = 1.6\text{mA}$, $R_L = 2.2\text{k}\Omega$ | - | - | 15 | |
| | | | $T_A = 25^\circ\text{C}$ | - | 1.35 | 10 | |
| T_{PLH} | Low to High Propagation Delay | 6N139 | $I_F = 0.5\text{mA}$, $R_L = 4.7\text{k}\Omega$ | - | - | 90 | μs |
| | | | $T_A = 25^\circ\text{C}$ | - | 15 | 60 | |
| | | 6N139 | $I_F = 12\text{mA}$, $R_L = 250\Omega$ | - | - | 10 | |
| | | | $T_A = 25^\circ\text{C}$ | - | 1.6 | 7 | |
| | | 6N138 | $I_F = 1.6\text{mA}$, $R_L = 2.2\text{k}\Omega$ | - | - | 50 | |
| | | | $T_A = 25^\circ\text{C}$ | - | 7.6 | 35 | |
| CM_H | Common Mode Transient Immunity at Logic High | $I_F = 0\text{mA}$, $ V_{CM} = 10V_{P-P}$, $T_A = 25^\circ\text{C}$, $R_L = 2.2\text{k}\Omega$ | 1,000 | - | - | $V/\mu\text{s}$ | |
| CM_L | Common Mode Transient Immunity at Logic Low | $I_F = 1.6\text{mA}$, $ V_{CM} = 10V_{P-P}$, $T_A = 25^\circ\text{C}$, $R_L = 2.2\text{k}\Omega$ | 1,000 | - | - | | |



Low Input Current Photodarlington Coupler

Typical Characteristic Curves

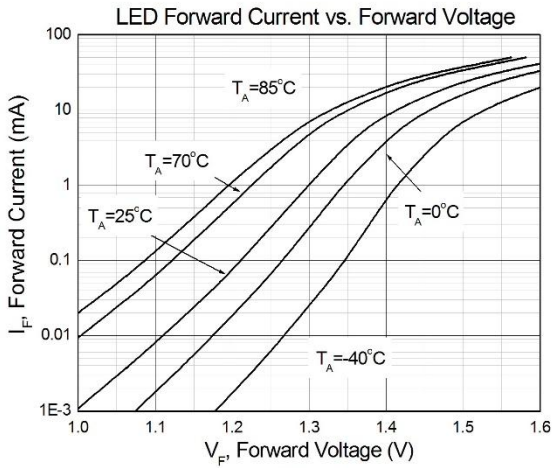

Figure 1

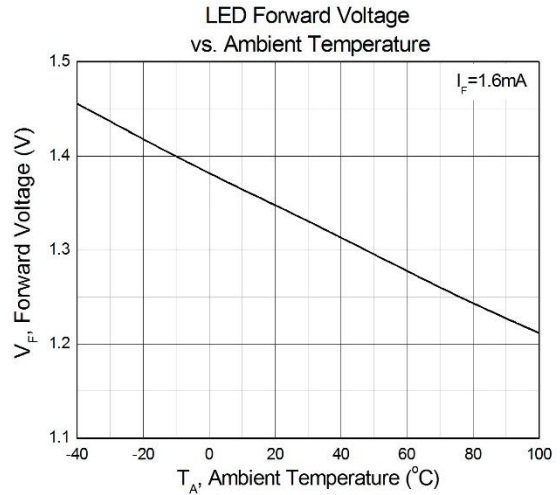

Figure 2

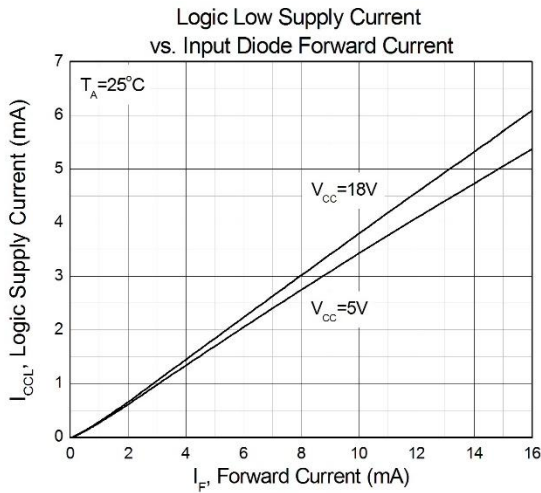

Figure 3

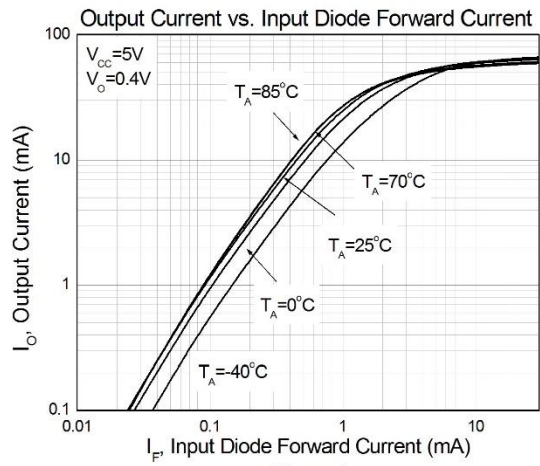

Figure 4

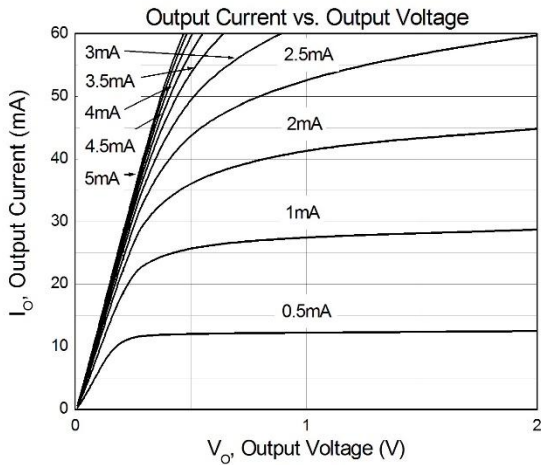

Figure 5

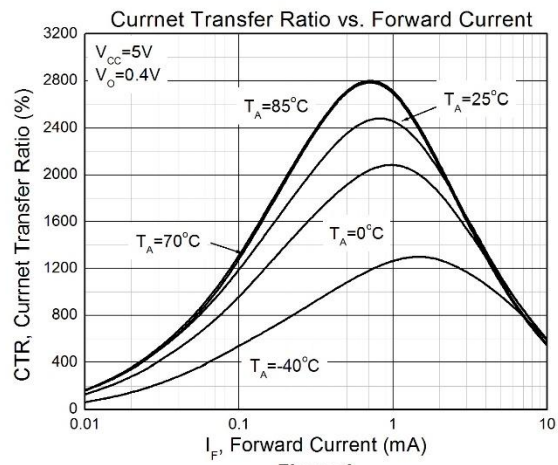
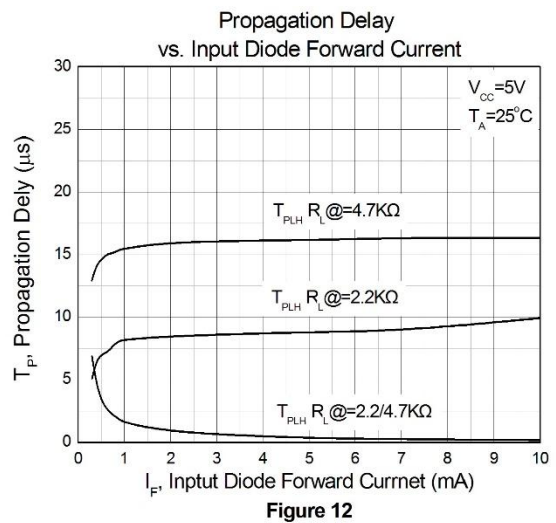
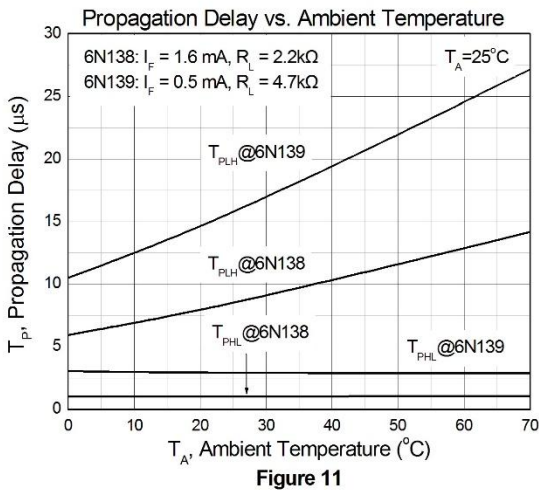
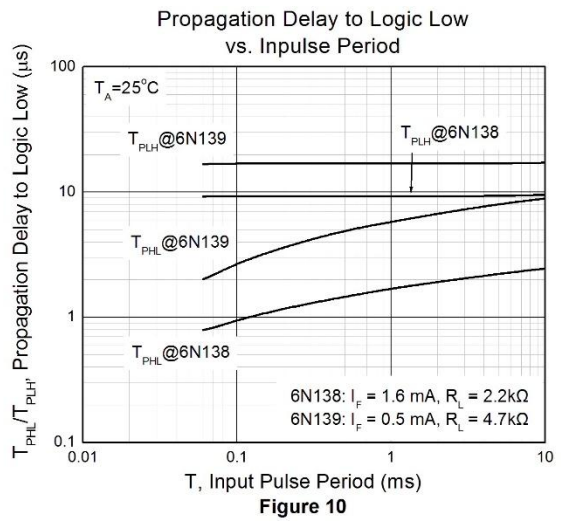
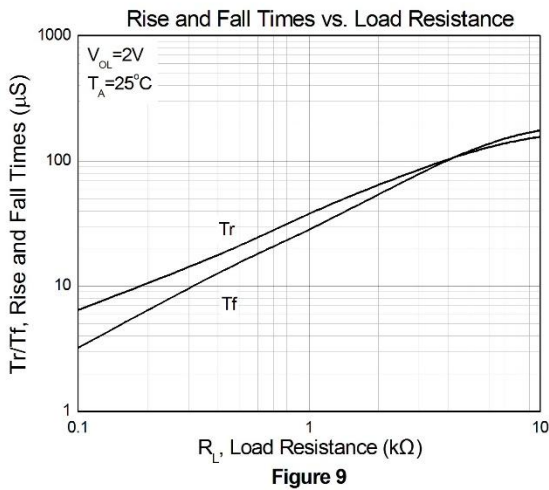
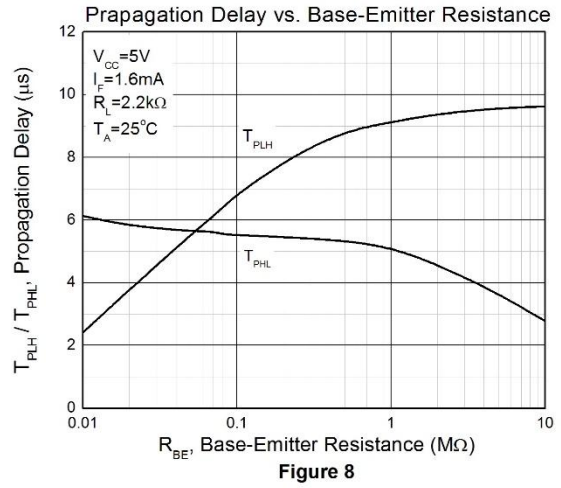
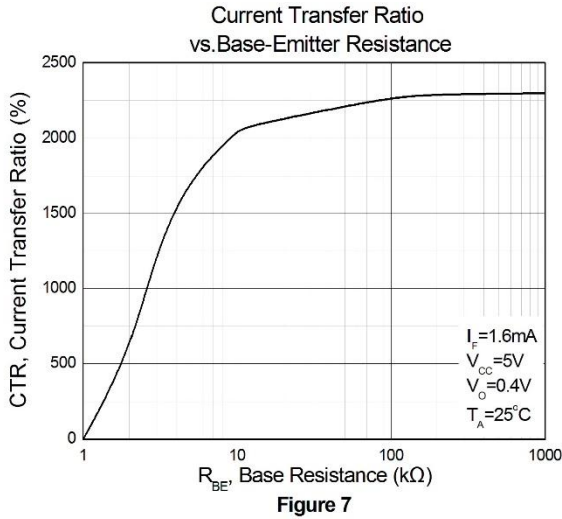

Figure 6



Low Input Current Photodarlington Coupler





Low Input Current Photodarlington Coupler

Test Circuits

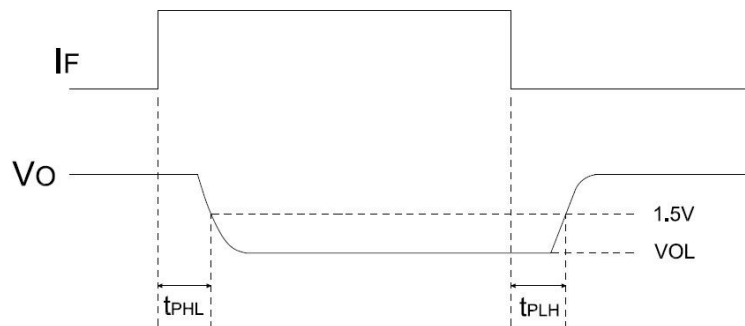
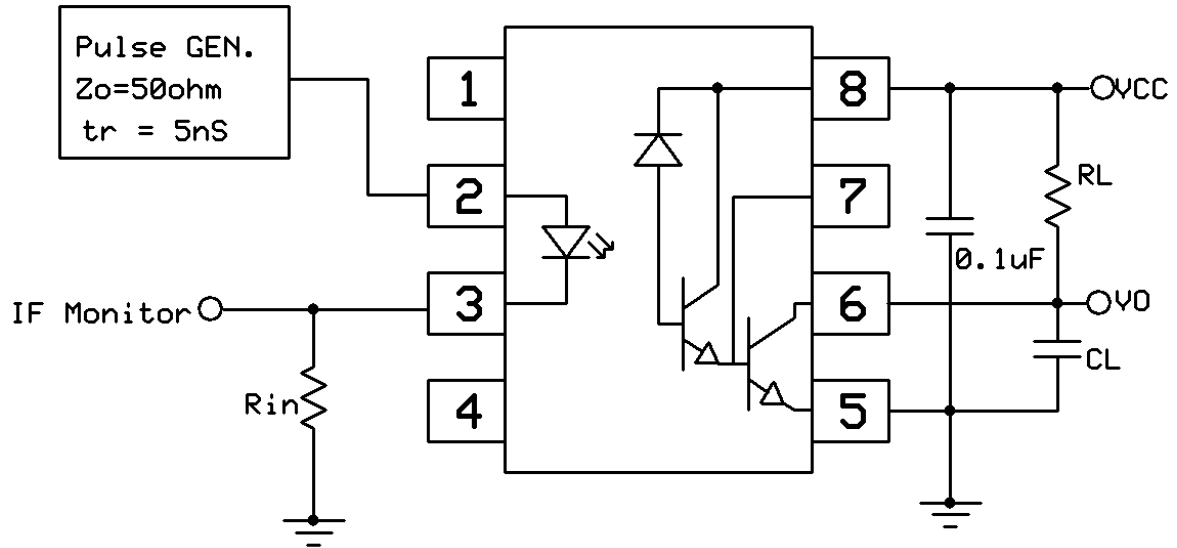

Switching Time Test Circuit



Low Input Current Photodarlington Coupler

Test Circuits

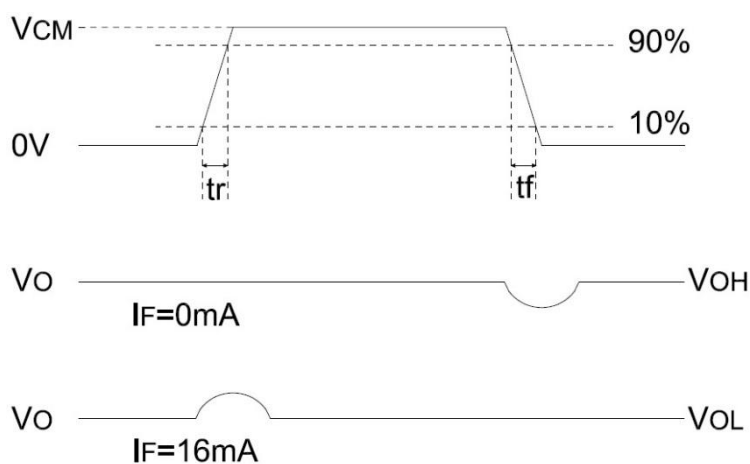
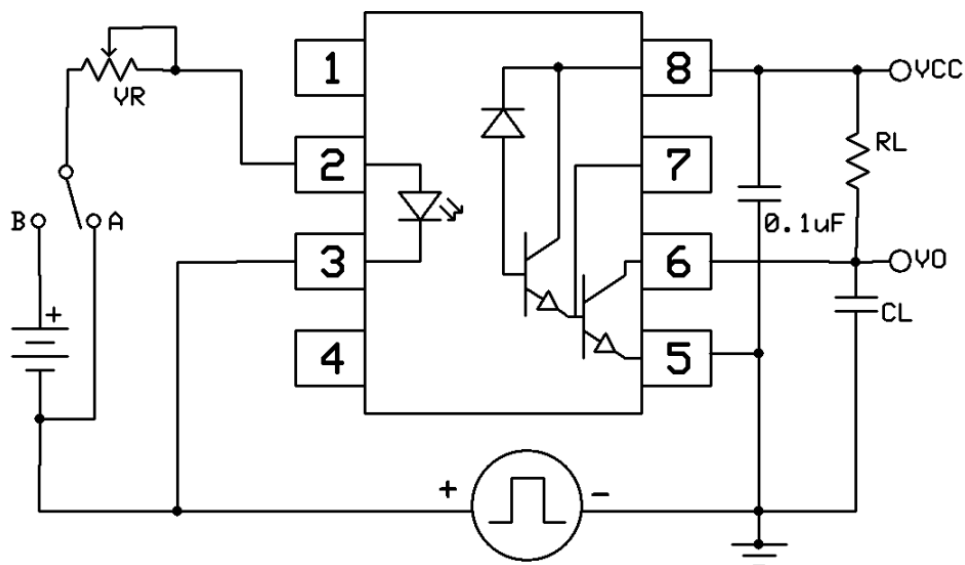

CMR Test Circuit



Low Input Current Photodarlington Coupler

Package Dimension *Dimensions in mm unless otherwise stated*

Standard DIP – Through Hole

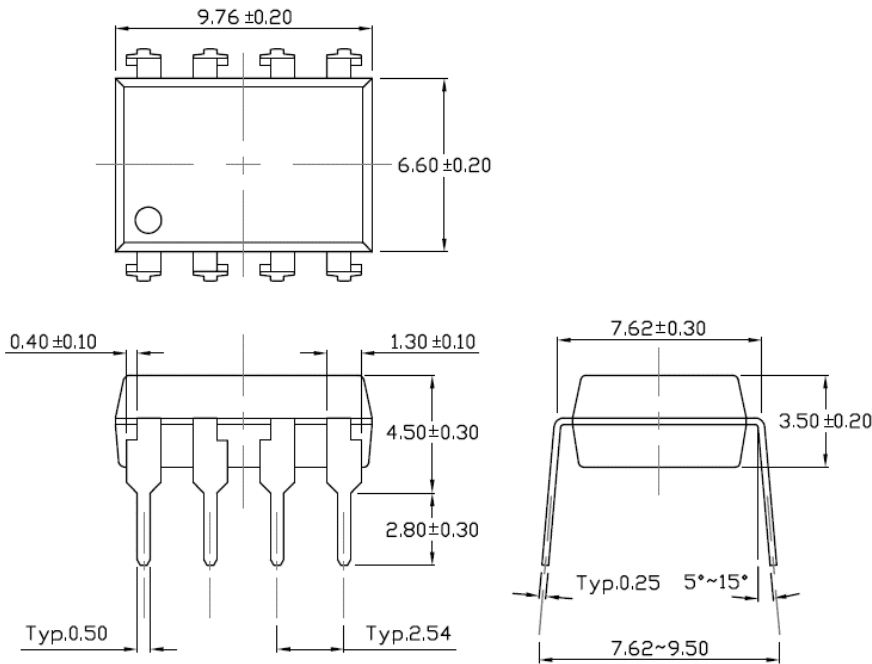

Gullwing (400mil) Lead Forming – Through Hole (M Type)

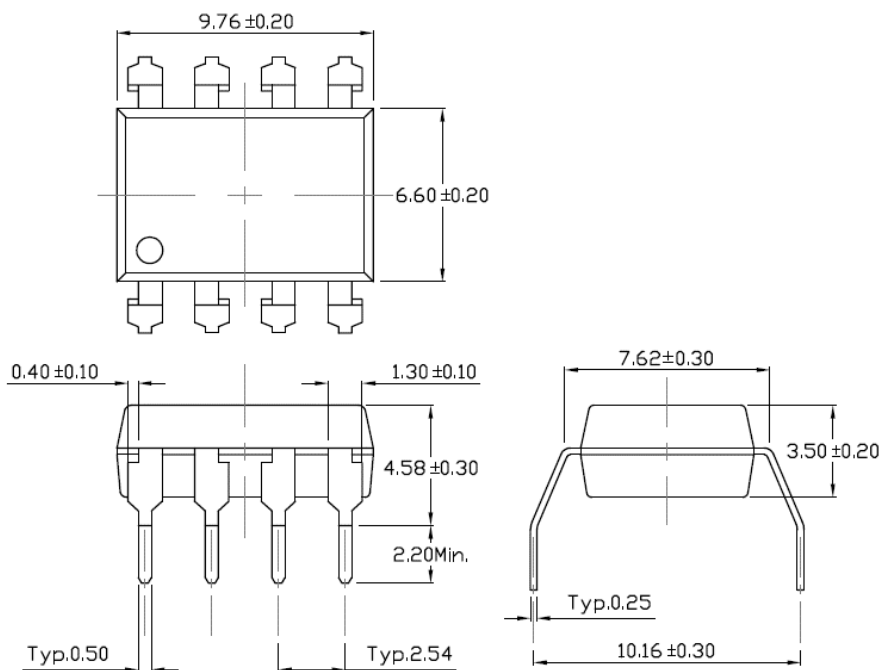



Low Input Current Photodarlington Coupler

Surface Mount Lead Forming (S Type)

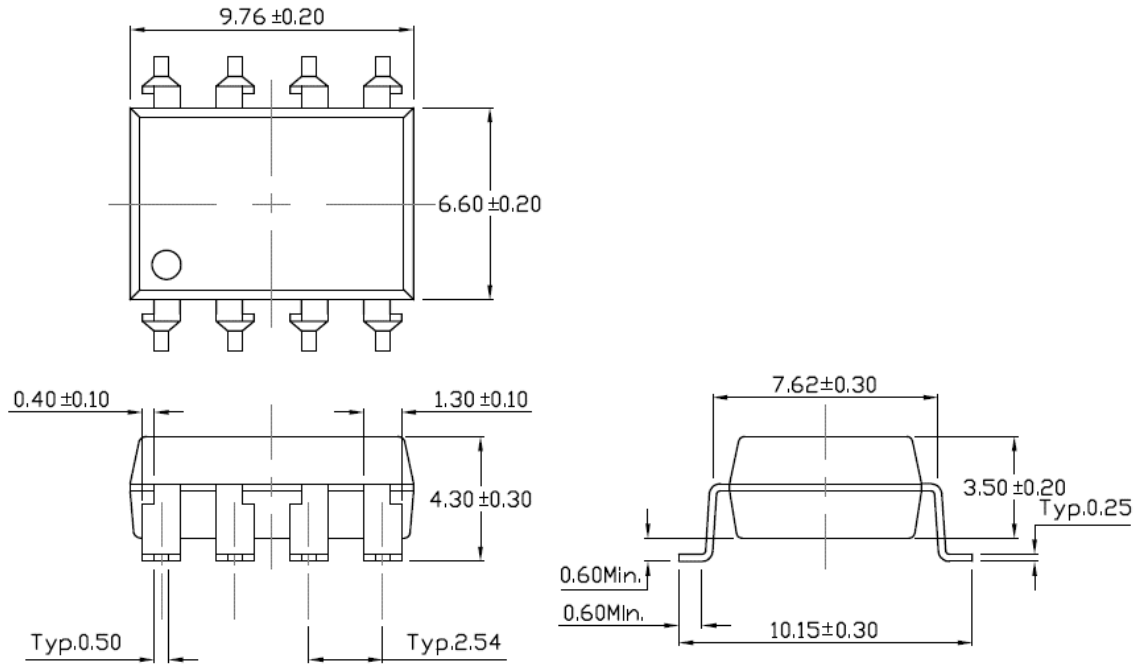

Surface Mount (Low Profile) Lead Forming (SL Type)

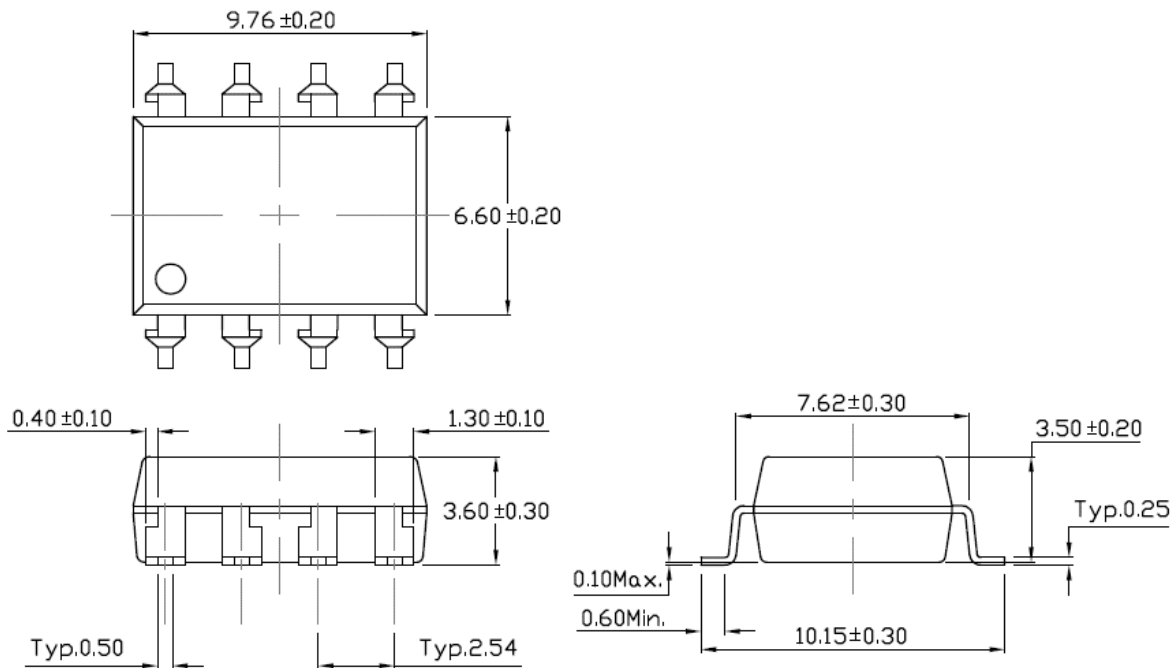



6N138, 6N139

Low Input Current Photodarlington Coupler

Recommended Solder Mask Dimensions in mm unless otherwise stated

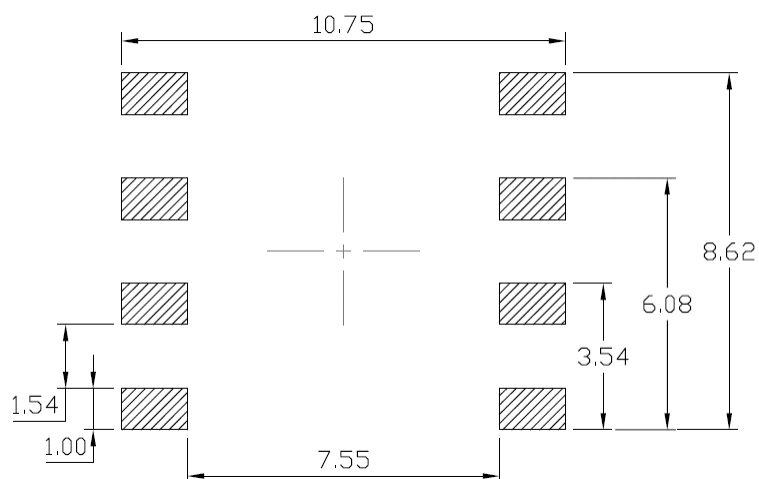

Device Marking

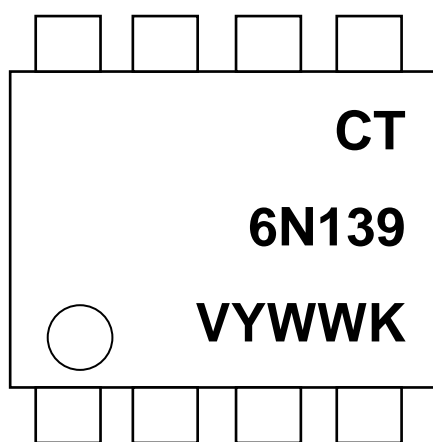

- CT : Denotes "CT Micro"
- 6N139 : Product Number
- V : VDE Option
- Y : Fiscal Year
- WW : Work Week
- K : Production Code



6N138, 6N139

Low Input Current Photodarlington Coupler

Ordering Information

6N13X(V)(Y)(Z)

X = Part No. (8 or 9)

V = VDE Option (V or None)

Y = Lead form option (S, SL, M or none)

Z = Tape and reel option (T1, T2 or none)

| Option | Description | Quantity |
|---------------|--|-----------------|
| None | Standard 8 Pin Dip | 40 Units/Tube |
| M | Gullwing (400mil) Lead Forming | 40 Units/Tube |
| S(T1) | Surface Mount Lead Forming – With Option 1 Taping | 1000 Units/Reel |
| S(T2) | Surface Mount Lead Forming – With Option 2 Taping | 1000 Units/Reel |
| SL(T1) | Surface Mount (Low Profile) Lead Forming– With Option 1 Taping | 1000 Units/Reel |
| SL(T2) | Surface Mount (Low Profile) Lead Forming– With Option 2 Taping | 1000 Units/Reel |



6N138, 6N139

Low Input Current Photodarlington Coupler

Carrier Tape Specifications *Dimensions in mm unless otherwise stated*

Option S(T1) & SL(T1)

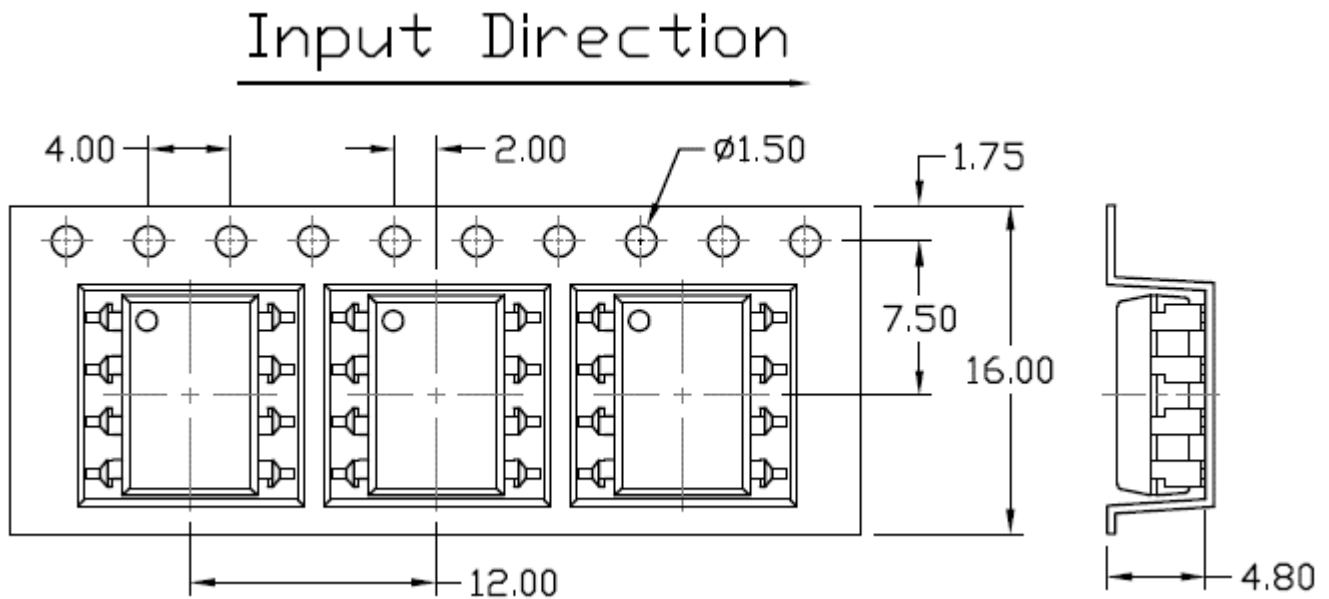

Option S(T2) & SL(T2)

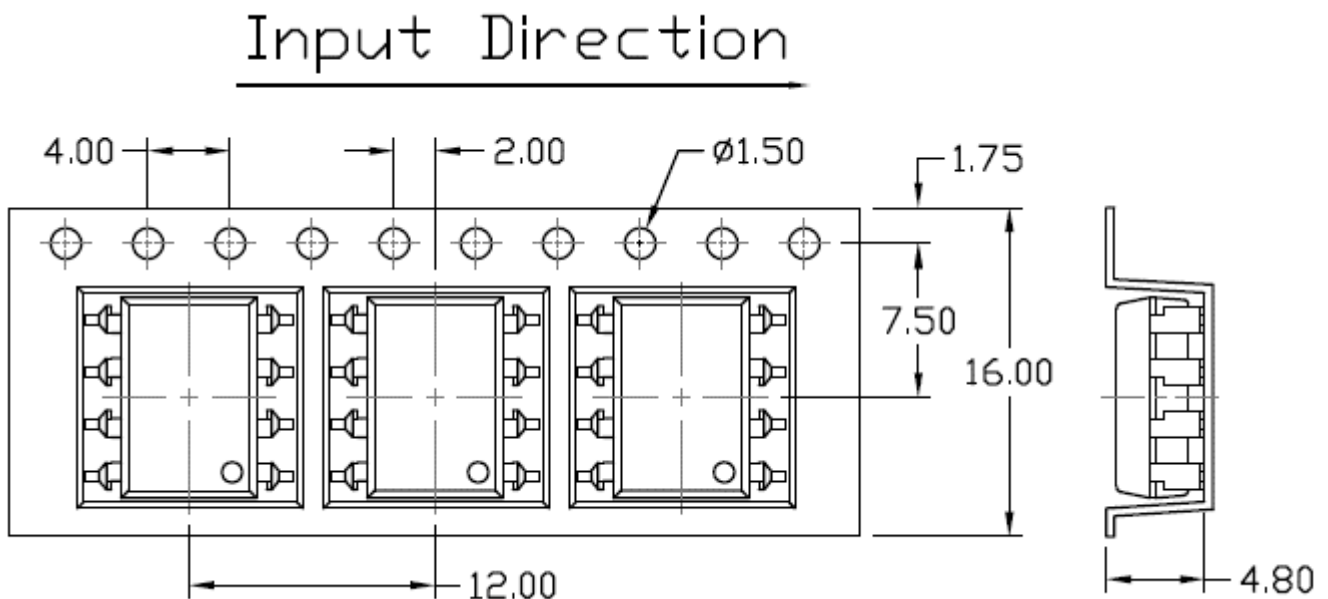



Low Input Current Photodarlington Coupler

Reflow Profile

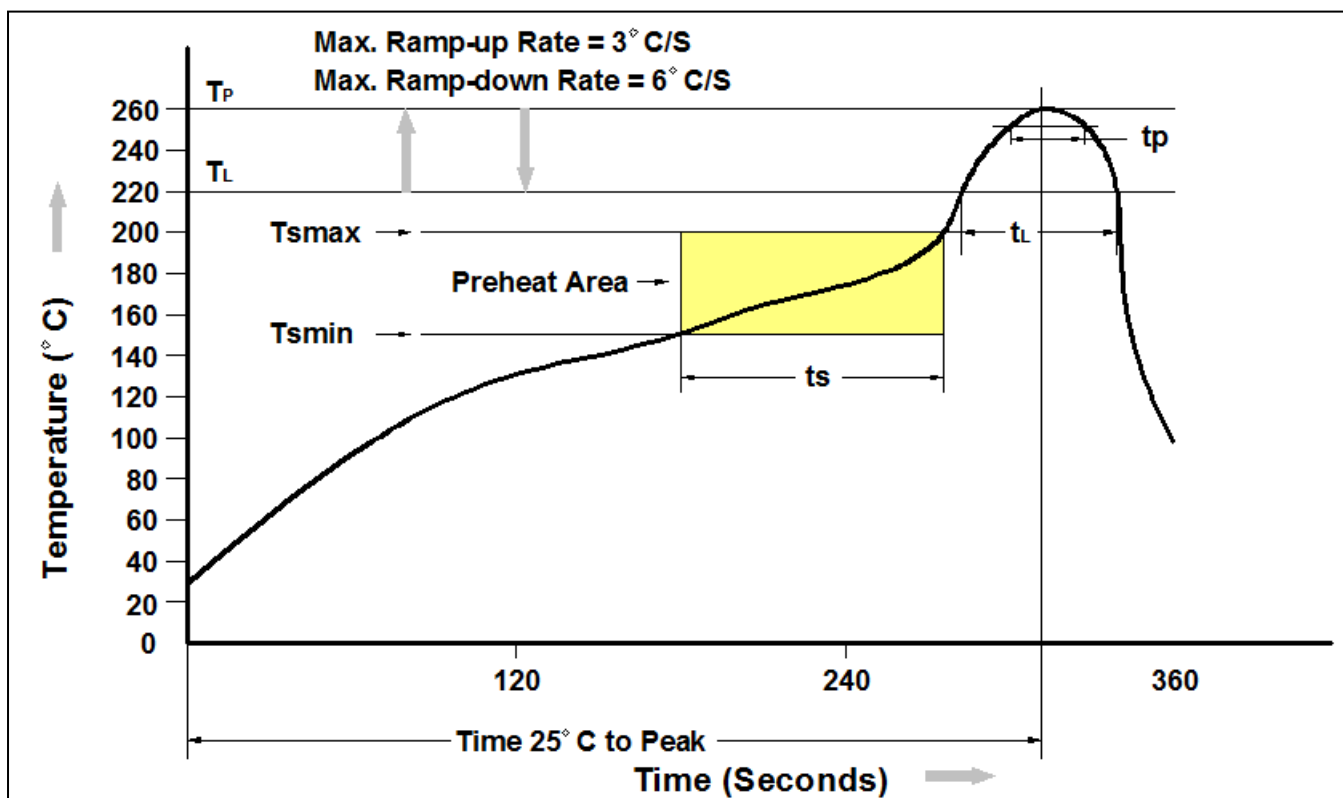

| Profile Feature | Pb-Free Assembly Profile |
|--|--------------------------|
| Temperature Min. (T_{smin}) | 150°C |
| Temperature Max. (T_{smax}) | 200°C |
| Time (t_s) from (T_{smin} to T_{smax}) | 60-120 seconds |
| Ramp-up Rate (t_L to t_P) | 3°C/second max. |
| Liquidous Temperature (T_L) | 217°C |
| Time (t_L) Maintained Above (T_L) | 60 – 150 seconds |
| Peak Body Package Temperature | 260°C +0°C / -5°C |
| Time (t_P) within 5°C of 260°C | 30 seconds |
| Ramp-down Rate (T_P to T_L) | 6°C/second max |
| Time 25°C to Peak Temperature | 8 minutes max. |



Low Input Current Photodarlington Coupler

DISCLAIMER

CT MICRO RESERVES THE RIGHT TO MAKE CHANGES WITHOUT FURTHER NOTICE TO ANY PRODUCTS HEREIN TO IMPROVE RELIABILITY, FUNCTION OR DESIGN. CT MICRO DOES NOT ASSUME ANY LIABILITY ARISING OUT OF THE APPLICATION OR USE OF ANY PRODUCT OR CIRCUIT DESCRIBED HEREIN; NEITHER DOES IT CONVEY ANY LICENSE UNDER ITS PATENT RIGHTS, NOR THE RIGHTS OF OTHERS.

CT MICRO ARE NOT AUTHORIZED FOR USE AS CRITICAL COMPONENTS IN LIFE SUPPORT DEVICES OR SYSTEMS WITHOUT EXPRESS WRITTEN APPROVAL OF CT MICRO INTERNATIONAL CORPORATION.

- 1. Life support devices or systems are devices or systems which, (a) are intended for surgical implant into the body, or (b) support or sustain life, or (c) whose failure to perform when properly used in accordance with instruction for use provided in the labelling, can be reasonably expected to result in significant injury to the user.*
- 2. A critical component is any component of a life support device or system whose failure to perform can be reasonably expected to cause the failure of the life support device or system, or to affect its safety or effectiveness.*